

# Powering Arduino MEGA2560 with a Higher Supply Voltage

## OVERVIEW

Let's say that you want to use the Arduino MEGA2560 in an application that only has a supply rail of 24V available. With a recommended VIN range of only 7V to 12V, the MEGA2560 is going to need a lower voltage rail to be developed from the 24V rail.

Winford Engineering product RDBKMEG1, a breakout board designed to be used with an Arduino MEGA2560, includes a useful feature that is specifically intended to easily solve this problem. A group of 3 pads (X1, GND, and VIN) are oriented so that a suitable 3-terminal DC/DC converter can be added. Powered from 24V, the DC/DC converter will provide an output voltage that is appropriate for the MEGA2560 (e.g., 9V).

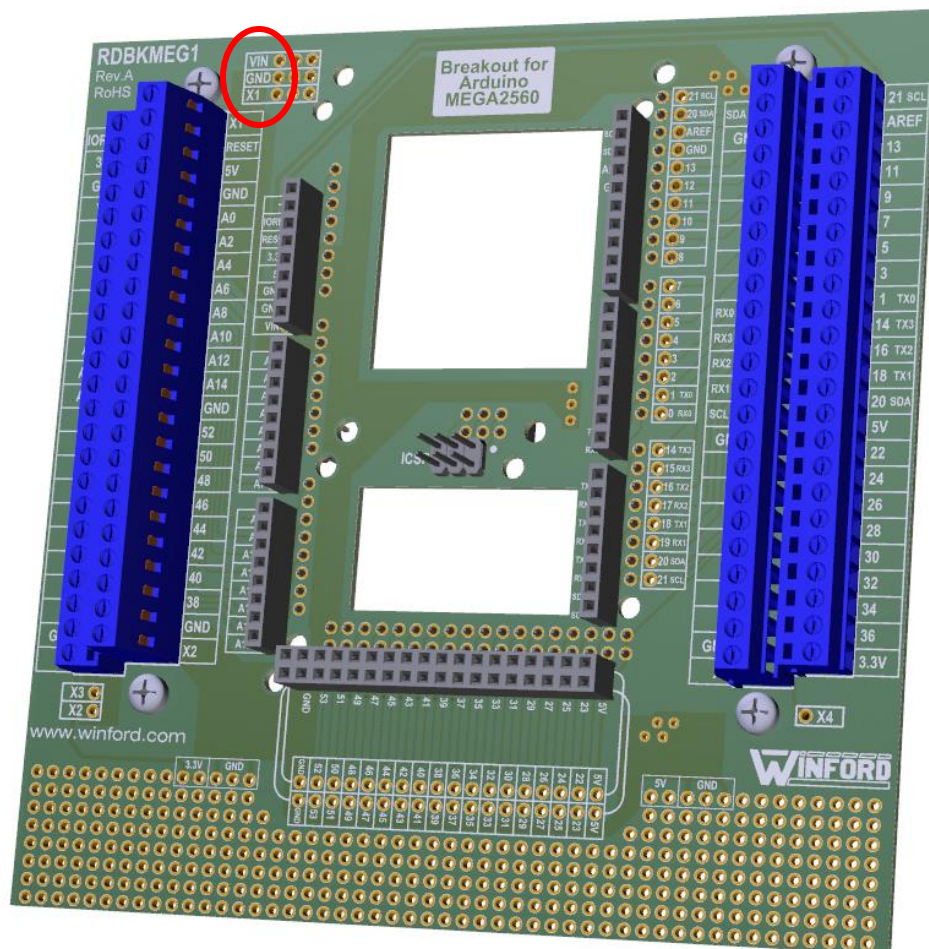

**PROCEDURE**

There are a number of 3-terminal DC-DC converters available. For reference, one reasonable option to consider is Recom Power part number R-78E9.0-0.5, which has an output of 9V (500mA rating) while accepting an input voltage range of 12V to 28V.

Simply solder the DC-DC converter onto the breakout board as indicated.

DC-DC Converter Pin	RDBKMEG1 Pad
Input (Pin 1)	X1
Ground (Pin 2)	GND
Output (Pin 3)	VIN

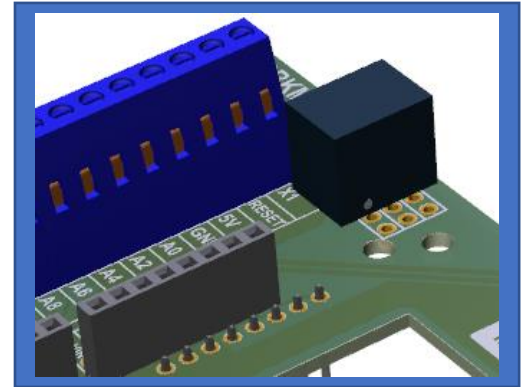

Now, plug the Arduino MEGA2560 into the RDBKMEG1 breakout board, and provide power (24V) to the X1 terminal block position. This will provide power to the input of the DC-DC converter, and the DC-DC converter output will provide 9V to VIN on the Arduino MEGA2560.

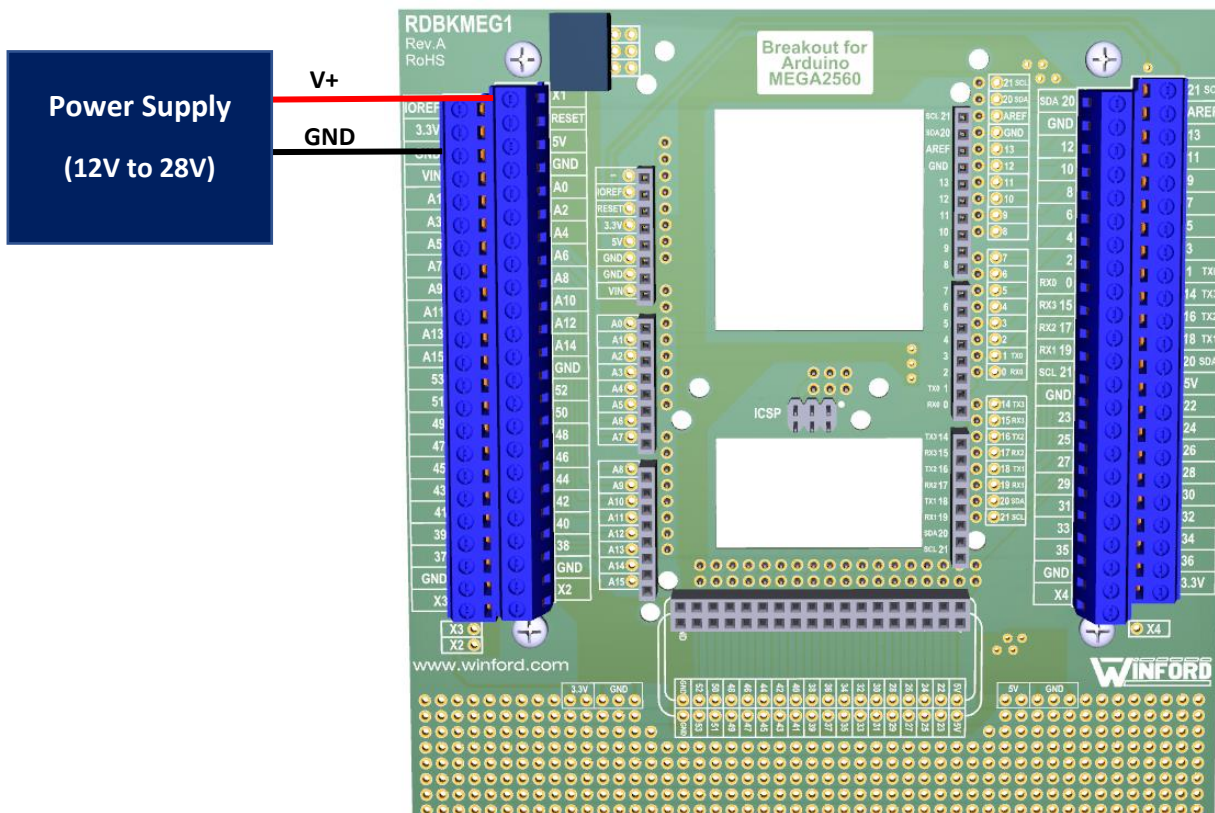

(Note that the power supply must be connected to terminal block position X1, not VIN!)