

4

3

2

1

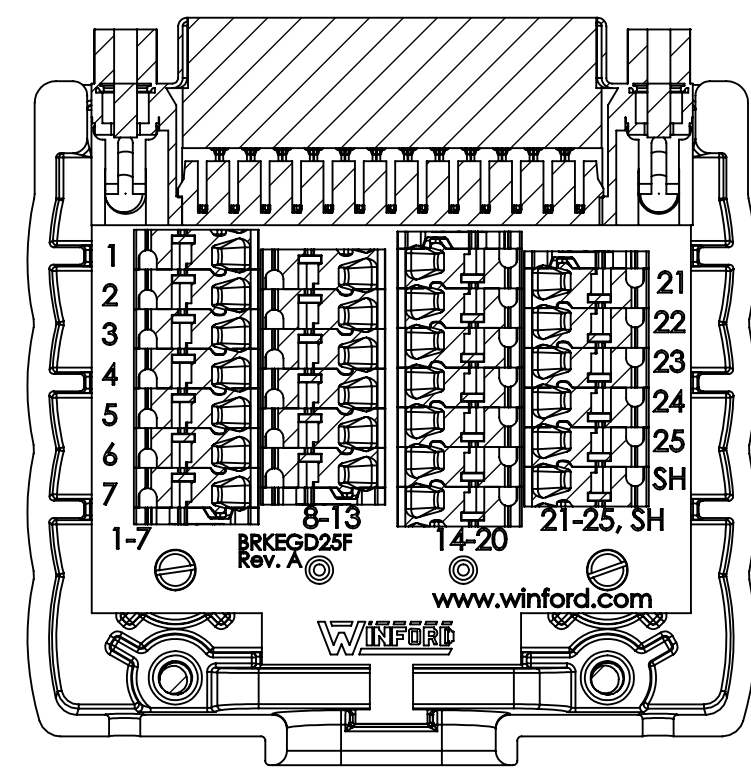
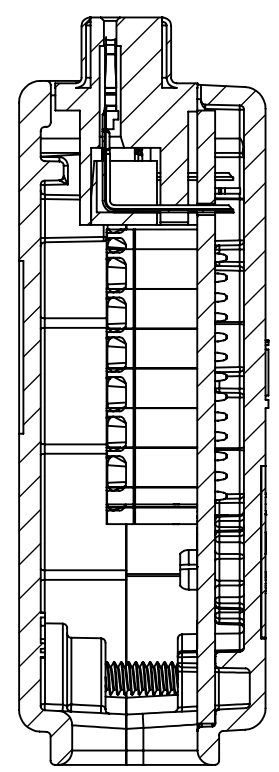
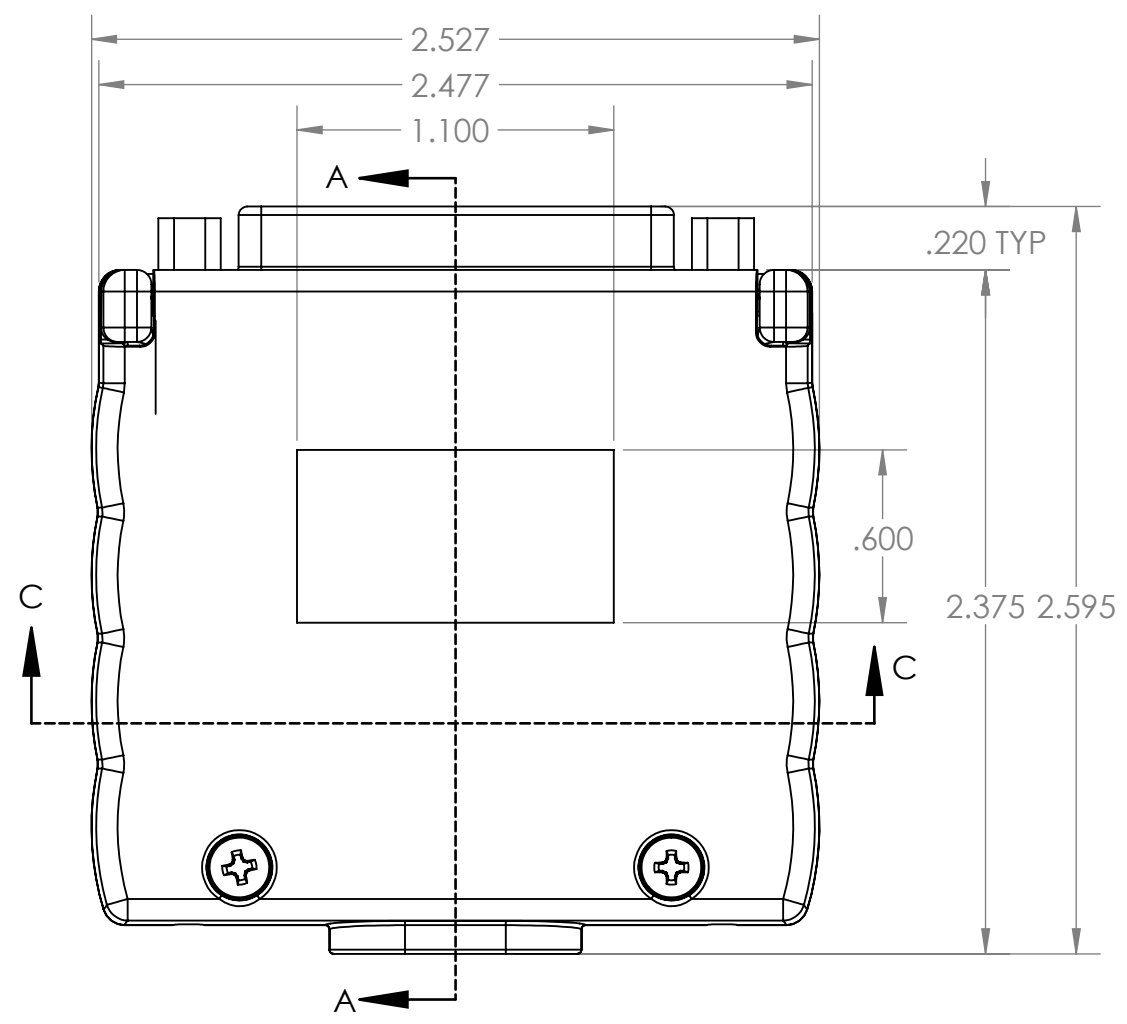

SECTION A-A

SECTION B-B

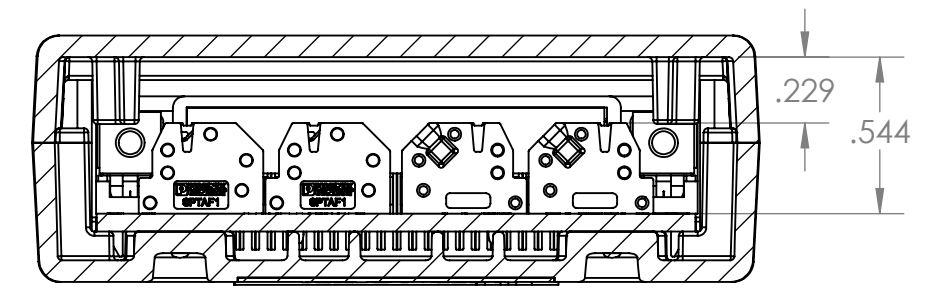
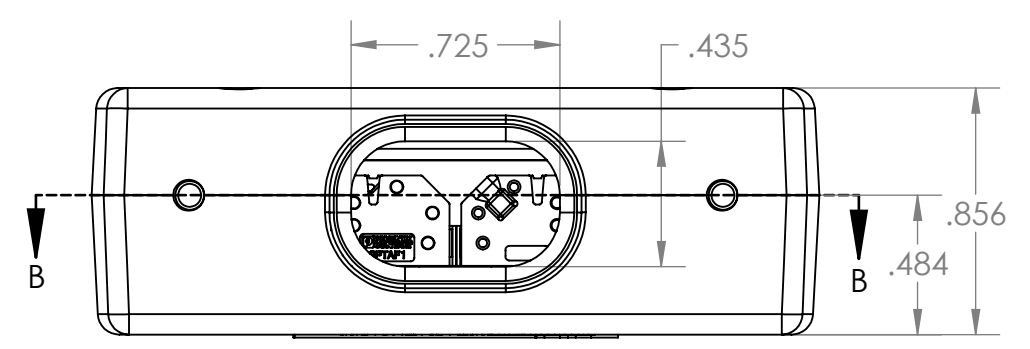

SECTION C-C

DIM: INCH	DATE: 12/13/2020	RoHS COMPLIANT: YES	DESCRIPTION:
 WINFORD ENGINEERING, LLC 4561 GARFIELD ROAD AUBURN, MI 48611			DB25 Breakout Board W/ Enclosure
			PART NUMBER (S)
www.winford.com	989-671-9721	BRKEGD25F-R	PART REVISION
			A

4

3

2

1